



Hall Research Technologies, Inc.

VGA-to-DVI Video Scaler

Converts and Scales Analog VGA or HDTV Component to DVI

Digital or Analog DVI output can be set to various PC or HDTV Resolutions!



Model SC-VD-2

UMA1062 Rev. D

**CUSTOMER
SUPPORT
INFORMATION**

Order toll-free in the U.S. 800-959-6439
FREE technical support, Call 714-641-6607 or fax 714-641-6698
Mail order: Hall Research Technologies, 1163 Warner Ave., Tustin, CA 92780
Web site: www.hallresearch.com • E-mail: info@hallresearch.com

[www. DVI Connect .com](http://www.DVIConnect.com)

TRADEMARKS USED IN THIS MANUAL

Hall Research, HRT, and  (logo) are trademarks of Hall Research Technologies, Inc. IBM are a registered trademark of International Business Machines Corporation.

Any other trademarks mentioned in this manual are acknowledged to be the property of the trademark owners.

FEDERAL COMMUNICATIONS COMMISSION RADIO FREQUENCY INTERFERENCE STATEMENT

This equipment generates, uses, and can radiate radio frequency energy and if not installed and used properly, that is, in strict accordance with the manufacturer's instructions, may cause interference to radio communication. It has been designed to comply with the limits for a Class A computing device in accordance with the specifications in Subpart B of Part 15 of FCC rules, which are intended to provide reasonable protection against such interference when the equipment is operated in a commercial environment. Operation of this equipment in a residential area is likely to cause interference, in which case the user at their own expense will be required to take whatever measures may be necessary to correct the interference.

Changes or modifications not expressly approved by the party responsible for compliance could void the user's authority to operate the equipment.



Table of Contents

1. Introduction 3
 1.1 General..... 3
 1.2 Features..... 4
2. Installation 4
 2.1 Input connection 4
 2.2 Output connection..... 5
 2.3 Connection Block Diagrams..... 5
3. Configuration & Operation..... 6
 3.1 Front and Rear Panels..... 6
 3.2 Menus and Adjustments 6
4. Troubleshooting..... 9
 Contacting Hall Research Technologies..... 9
 Shipping and Packaging 9
5. Specifications..... 9
 Input Resolutions..... 10
 Output Resolutions 10
 Reference Information..... 10

Hall Research Technologies, Inc.

Home of the Mini-Cat®

1. Introduction

1.1 General

The SC-VD-2 is a high performance PC/HDTV scaler that accepts analog RGB inputs (VGA or Component) and converts it to DVI-I (digital + analog) output.

The input to the SC-VD-2 is analog PC or HDTV signal (RGBHV, YPbPr, or YCbCr).

The output of the SC-VD-2 is digital + analog PC or HDTV DVI signal with a format of digital RGBHV bit-stream plus analog RGBHV, known as DVI-I (Integrated digital and analog).

The input resolution is automatically detected while the output resolution and refresh rate can be selected through OSD menu and front panel push buttons.

DVI output enables an all digital rendering of video without the losses associated with an analog interface and is ideal for use with digital displays such as LCD, plasma or DLP projectors.

The SC-VD-2 Video Processor combines the functions of a video scaler, scan-converter, and format transformer and is packed into a compact and durable metal housing with easy-to-use touch buttons.

The controls include input/output setup picture adjustment, H/V phase adjustment, System information and many other advanced options.

The SC-VD-2 allows you to specify a resolution and refresh rate for its output. Then it will output a steady (uninterrupted) DVI signal to your display device at your specified rate regardless of the input. This effectively allows any VGA switch, such as HRT's VS-2 or VS-4, to become a seamless switch with DVI output option. The output timing is constant regardless of what is happening at the input. So when you switch from one input to another, the display device does not see any interruption in the signal coming to it.



1.2 Features

- Converts analog VGA from any PC (or component from any DVD player) to Digital DVI output.
- Ideal for use with digital displays such as LCD, plasma, or DLP projectors.
- Digital output reduces losses associated with analog signals.
- The resolution of any PC or HDTV video signal can be scaled up or scaled down to any other PC or HDTV resolution. It can also change the frame rate of the output.
- 50 MB Video memory for real-time frame rate conversion.
- Signal format conversion between RGBHV and YPbPr.
- Input: PC(VGA/SVGA/XGA/SXGA) + HDTV(480i 576i 480p 567p 720p 1080i), @ 60 to 85 Hz
- Output: PC(VGA/SVGA/XGA/SXGA) + HDTV(480p/576p/720p/1080i)
- Automatically detects input mode and timing parameters
- Allows fine-tuning the output picture to optimum through adjustment of sampling clock, phase, and position on screen.
- Easy- to- use push buttons and OSD menu control.

2. Installation

2.1 Input connection

The SC-VD-2 can accept both PC and HDTV inputs. When accepting a PC input use the 15-pin D-sub cable to connect the output of a PC device to the input connector labeled PC/HDTV on the back of SC-VD-2.

When accepting a HDTV input use a 15-pin D-sub to YPbPr/3 RCA cable to connect the YPbPr output (or YCbCr) of a HDTV device to the PC/HDTV input connector of the SC-VD-2.

The SC-VD-2 can automatically detect the mode and resolution of the PC/HDTV input (The mode can also be forced via OSD menu).

2.2 Output connection

The SC-VD-2 can output a variety of PC resolutions and HDTV progressive resolutions, in both digital and analog format.

To use the SC-VD-2's digital output select DVI-D in the Output Setup of the menu, and use a DVI cable to connect the DVI output of the SC-VD-2 to the DVI input of a display monitor, or HDTV device.

To use analog output of the SC-VD-2, select DVI-A in the Output Setup of the menu, and use the DVI to VGA adaptor or cable to translate the analog outputs in the DVI connector into VGA configuration to connect to a VGA monitor or to connect to the YPbPr input of a HDTV device through a VGA to YPbPr/3RCA adaptor cable.

2.3 Connection Block Diagrams

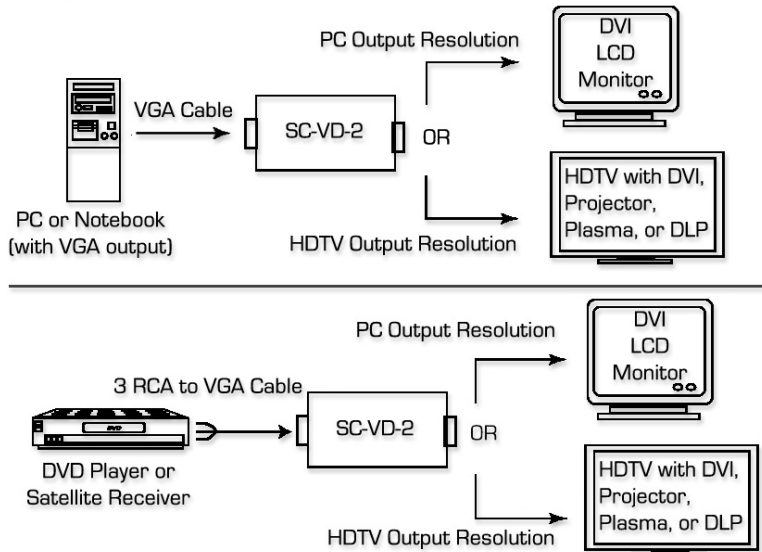

In the above diagrams the output of the SC-VD-2 is set to digital DVI. If you set the output to Analog DVI, you can use an analog LCD monitor and or HDTV; however you will need adapters or cables for connection to the unit.

3. Configuration & Operation

3.1 Front and Rear Panels



3.2 Menus and Adjustments

Pressing the Menu button will bring up the OSD menu controls on the screen as follows:

- Input set up
- Output set up
- Picture Adjust
- HV Adjust
- OSD Adjust
- System Information
- Auto Adjust
- Exit

Use + or - to move the arrow cursor to your desired selection, then press MENU to confirm your selection and enter into that sub menu.

Input set up - When selected, a sub menu of clock, phase, and input mode is shown.

Clock 32/64
 Phase 22/32
 YPBPR ... ✓ RGB

Use + or - to choose the parameter you want to adjust and then press Menu (Enter) to highlight your selection. Once a parameter is high-lighted use + or - to increase or decrease the setting value. Press Menu (Enter) again to leave the setting. Move the arrow to exit then press Menu/Enter to Exit.

Clock: Used to adjust for optimal input clock frequency for a stable picture. Pressing + narrows the width of the picture toward the left. Pressing - extends the width of the picture toward the right.

Phase: Used to adjust for lowest noise of the picture (edge tearing).







YPbPr RGB: The SC-VD-2 automatically detects and shows the input format as YPbPr or RGB. However, you can manually select the YPbPr or RGB to match the format of your input. Selecting a format that doesn't coincide with your input will result in an abnormal picture.

Output set up - When selected, a sub-menu appears for the *DVI output format* (analog or digital) and *Output Mode* (refresh-rate and resolution).

Output Modes (Under DVI-D, YPbPr outputs are not available)

	PC Resolutions	HDTV Resolutions	
VGA	640 X 480@60/72/75/85Hz	1080i-RGB	1920 X 1080@60Hz
VGA 70	720 X 400@70Hz	720p-RGB	1280X 720@60Hz
VESA 85	640 X 400@85Hz	576p-RGB	720X 576@60Hz
SVGA	800 X 600@60/72/75/85Hz	480p-RGB	720 X 480@60Hz
XGA	1024 X 768@60/70/75/85Hz	1080i-YPbPr	1920 X 1080@60Hz
Mac	1152 X 864@ 70/75Hz	720p-YPbPr	1280 X 720@60Hz
WXGA	1280 X 768@60Hz	576p-YPbPr	720 X 576@60Hz
1280A	1280 X 960@60Hz	480p-YPbPr	720 X 480@60Hz
SXGA	1280 X 1024@60/75Hz		

Picture Adjust - When selected the following adjust parameters will appear:

Contrast		070
Bright		130
Color		070
Red		128
Green		128
Blue		128
Reset		
Exit		

The factory preset values are shown above

Select reset to reset all adjustment back to the factory preset values.

HV adjust - When selected the following sub-menu appears.

H-position  184
V-position  32

Use + - to adjust the best horizontal and vertical position of the picture.

OSD adjust - When selected, you can adjust the Horizontal and Vertical position of the OSD menu.

System information - When selected, it shows the input/output resolutions and their vertical refresh rates on the screen.

Auto adjust - When selected the SC-VD-2 will automatically adjust all the parameter to the factory preset value.

Exit - Select to exit from the current menu page.

Notes

- ❖ The default output resolution is XGA @ 60Hz.
- ❖ The unit has non-volatile memory. It saves all your settings before power off, and recalls those settings on next power on.

Quickly Jumping to XGA or 480p Output

At any time, pressing + and - buttons simultaneously for a few seconds will reset the output resolution to XGA@60Hz, and other settings back to factory default values. Pressing the Menu and – together for a few seconds will choose 480P output mode.

4. Troubleshooting

There are no field serviceable parts or circuits in the device. If you think that the device is malfunctioning (or you have no picture output), please first try to reset to factory default settings by pressing the “+” and “-” buttons (or “menu” and “-” buttons) simultaneously for 2 seconds (See above).

Contacting Hall Research Technologies

If you determine that your scaler is malfunctioning, do not attempt to repair the unit. Contact HRT’s Tech. Support at 714-641-6607.

Before you do, make a record of the history of the problem. We will be able to provide more efficient and accurate assistance if you have a complete description.

Shipping and Packaging

If you need to transport or ship your Video Processor:

- Package it carefully. We recommend that you use the original container.
- Before you ship the units back to Hall Research Technologies for repair or return, contact us to get a Return Authorization (RMA) number.

5. Specifications

General

Input Format:	Analog RGBHV, YPbPr, YCbCr
Input Signal:	RGB: 0.7Vp-p, 75 ohm, HV: 3 to 5 Vp-p TTL Y: 1 Vp-p 75 ohm; PbPr: 0.7 Vp-p 75 ohm
Input Connector:	HD-15 Female VGA
Output Format:	Digital RGBHV or Analog RGBHV or Analog YPbPr
Output Connector:	29-pin DVI-I
Power:	5V DC at 2 A max (Universal power supply included)

Input Resolutions

	PC Resolutions		HDTV Resolutions
VGA	640 X 480@60/72/75/85Hz	1080i	1920 X 1080@60Hz
VGA 70	720 X 400@70Hz	720p	1280X 720@60Hz
VESA 85	640 X 400@85Hz	576p	720X 576@50Hz
SVGA	800 X 600@60/72/75/85Hz	576i	720X 576@50Hz
XGA	1024 X 768@60/70/75/85Hz	480p	720 X 480@60Hz
Mac	1152 X 864@ 70/75Hz	480i	720 X 480@60Hz
WXGA	1280 X 768@60Hz		
1280A	1280 X 960@60Hz		
SXGA	1280 X 1024@60/75Hz		

Output Resolutions (Under DVI-D, YPbPr outputs are not available)

	PC Resolutions		HDTV Resolutions
VGA	640 X 480@60/72/75/85Hz	1080i-RGB	1920 X 1080@60Hz
VGA 70	720 X 400@70Hz	720p-RGB	1280X 720@60Hz
VESA 85	640 X 400@85Hz	576p-RGB	720X 576@60Hz
SVGA	800 X 600@60/72/75/85Hz	480p-RGB	720 X 480@60Hz
XGA	1024 X 768@60/70/75/85Hz	1080i-YPbPr	1920 X 1080@60Hz
Mac	1152 X 864@ 70/75Hz	720p-YPbPr	1280 X 720@60Hz
WXGA	1280 X 768@60Hz	576p-YPbPr	720 X 576@60Hz
1280A	1280 X 960@60Hz	480p-YPbPr	720 X 480@60Hz
SXGA	1280 X 1024@60/75Hz		

Reference Information

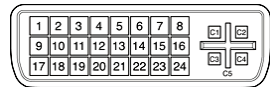

DVI Connector pinout N/U = Not Used

Pin	Signal name	Pin	Signal name
1	TMDS Data2-	13	TMDS Data3+ (N/U)
2	TMDS Data2+	14	+5V Power
3	TMDS Data2/4 Shield	15	Ground for +5V Power
4	TMDS Data4- (N/U)	16	Hot Plug Detect
5	TMDS Data4+ (N/U)	17	TMDS Data0-
6	DDC Clock	18	TMDS Data0+
7	DDC Data	19	TMDS Data0/5 Shield
8	Analog vertical sync	20	TMDS Data5- (N/U)
9	TMDS Data1-	21	TMDS Data5+ (N/U)
10	TMDS Data1+	22	TMDS Clock Shield
11	TMDS Data1/3 Shield	23	TMDS Clock+
12	TMDS Data3- (N/U)	24	TMDS Clock-
C1	Analog red	C4	Analog horizontal sync
C2	Analog green	C5	Analog ground
C3	Analog blue		



The difference between a “good” installation and a “great” one!™



Products Designed and Made in the USA

© Copyright 2008. Hall Research Technologies, Inc.
All rights reserved.

**1163 Warner Ave., Tustin, CA 92780
Ph: (714)641-6607, Fax: (714)641-6698**